

MJ05

165°液压铰链 (固装)

Series hydraulic soft-close hinges (indivisible)

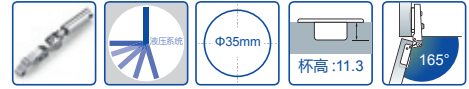

产品描述

Product Description

开启角度: 165 度
 门可选用板厚度: 14-26 毫米
 面板尺寸 (K): 3-8 毫米
 铰杯高度: 11.3 毫米
 铰杯直径: 35 毫米
 铰杯两孔距离: 48 毫米

Open degree: 165°
 Range of doors thickness: 14-26mm
 Height of hinge cup: 11.3mm
 Diameter of hinge cup: 35mm
 Diameter of door (K): 3-8mm
 Distance of two hole center: 48mm

应用实例

Applied Instance

H= 安装板高度
 K= 门板外线与铰链杯钻孔距离
 D= 侧板上所需盖位
 A= 门与侧板的间隙
 L= 面板内线侧边外线距离



H=height of mounting plate
 K=drilling distance from the edge of door to the edge of the hole
 D=required door overlay
 A=gap between door and side panel
 L=gap between door and carcass

安装尺寸

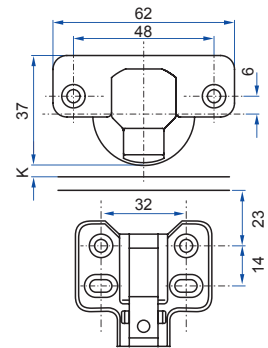
Installation Dimension

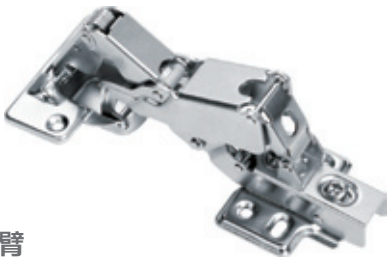

型号对照 Model Comparison

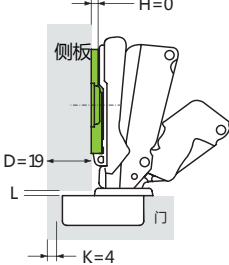
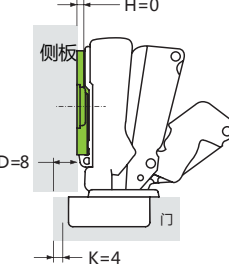
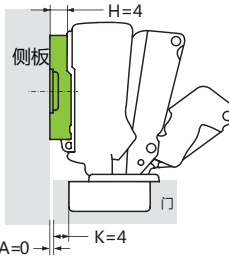
直臂 Full overlay (全盖门)	中曲 Half overlay (半盖门)	大曲 Insert (内嵌门)																																																																																																																														
订货号: MJ0509 	订货号: MJ0508 	订货号: MJ0507 																																																																																																																														
																																																																																																																																
<table border="1"> <tr> <td>底板高度 H mm</td> <td colspan="6">铰杯距离 K mm</td> </tr> <tr> <td></td> <td>3</td><td>4</td><td>5</td><td>6</td><td>7</td><td>8</td> </tr> <tr> <td></td> <td colspan="6">盖位 D mm</td> </tr> <tr> <td>0</td> <td>17</td><td>18</td><td>19</td><td>20</td><td>21</td><td>22</td> </tr> <tr> <td>2</td> <td>15</td><td>16</td><td>17</td><td>18</td><td>19</td><td>20</td> </tr> <tr> <td colspan="7">铰链底座高度 H=14+K-D</td> </tr> </table>	底板高度 H mm	铰杯距离 K mm							3	4	5	6	7	8		盖位 D mm						0	17	18	19	20	21	22	2	15	16	17	18	19	20	铰链底座高度 H=14+K-D							<table border="1"> <tr> <td>底板高度 H mm</td> <td colspan="6">铰杯距离 K mm</td> </tr> <tr> <td></td> <td>3</td><td>4</td><td>5</td><td>6</td><td>7</td><td>8</td> </tr> <tr> <td></td> <td colspan="6">盖位 D mm</td> </tr> <tr> <td>0</td> <td>8</td><td>9</td><td>10</td><td>11</td><td>12</td><td>13</td> </tr> <tr> <td>2</td> <td>6</td><td>7</td><td>8</td><td>9</td><td>10</td><td>11</td> </tr> <tr> <td colspan="7">铰链底座高度 H=5+K-D</td> </tr> </table>	底板高度 H mm	铰杯距离 K mm							3	4	5	6	7	8		盖位 D mm						0	8	9	10	11	12	13	2	6	7	8	9	10	11	铰链底座高度 H=5+K-D							<table border="1"> <tr> <td>底板高度 H mm</td> <td colspan="6">铰杯距离 K mm</td> </tr> <tr> <td></td> <td>3</td><td>4</td><td>5</td><td>6</td><td>7</td><td>8</td> </tr> <tr> <td></td> <td colspan="6">盖位 D mm</td> </tr> <tr> <td>0</td> <td>-1</td><td>-2</td><td>-3</td><td>-4</td><td>-5</td><td>-6</td> </tr> <tr> <td>2</td> <td>1</td><td>0</td><td>-1</td><td>-2</td><td>-3</td><td>-4</td> </tr> <tr> <td colspan="7">铰链底座高度 H=-2+K-A</td> </tr> </table>	底板高度 H mm	铰杯距离 K mm							3	4	5	6	7	8		盖位 D mm						0	-1	-2	-3	-4	-5	-6	2	1	0	-1	-2	-3	-4	铰链底座高度 H=-2+K-A						
底板高度 H mm	铰杯距离 K mm																																																																																																																															
	3	4	5	6	7	8																																																																																																																										
	盖位 D mm																																																																																																																															
0	17	18	19	20	21	22																																																																																																																										
2	15	16	17	18	19	20																																																																																																																										
铰链底座高度 H=14+K-D																																																																																																																																
底板高度 H mm	铰杯距离 K mm																																																																																																																															
	3	4	5	6	7	8																																																																																																																										
	盖位 D mm																																																																																																																															
0	8	9	10	11	12	13																																																																																																																										
2	6	7	8	9	10	11																																																																																																																										
铰链底座高度 H=5+K-D																																																																																																																																
底板高度 H mm	铰杯距离 K mm																																																																																																																															
	3	4	5	6	7	8																																																																																																																										
	盖位 D mm																																																																																																																															
0	-1	-2	-3	-4	-5	-6																																																																																																																										
2	1	0	-1	-2	-3	-4																																																																																																																										
铰链底座高度 H=-2+K-A																																																																																																																																